



(/media/filer_public_thumbnails/filer_public/a4/97/a497e78b-2287-4190-bfbc-b252d151fb99/genisism_sliding_table_panel_saw.jpg__1024x768_q85_subsampling-2.jpg)

Genesis XM-MANUAL

The Genesis 'X' series of sliding table panel saws must be one of the finest machines available on the market with every part of the machine designed for a purpose as opposed to a price. The structure of the machine and the construction are designed to withstand even the most demanding of cutting requirements with the frames being manufactured from heavy gauge steel which is laser cut and finger jointed ensuring strength and accuracy for the long term. Additional torsion bars are fitted to the base of the machine, again ensuring a structurally sound rigid base and frame, eliminating the possibility of flexing during operation and ensuring accurate and chip free cutting.

- 3200 mm sliding table of multi chamber construction running on solid and hardened steel runners with large diameter 'dumb bell rollers' to ensure an easy gliding motion.
- 1300mm rip fence mounted on a solid hardened and chromed 50mm diameter bar
- Fine adjustment to the rip fence
- Powerful 5.5 Kw (7.5Hp) motor
- 4 blade speeds by easily accessible manual belt change
- Independent scoring saw

- Adjustments for the scorer external to the machine for ease of setting and adjustment
- Both raise and lower and blade tilting handwheels situated at the front of the machine
- LED display to the blade tilt.
- Heavy duty, large section crosscut fence, telescopic with flat scales for ease of use.
- Quick release of cross cut fence for cutting solid wood or ripping larger panels.
- 2 x heavy duty flip stops, the action in a self lubricating bush to ensure long term accuracy.
- Self supported over head safety guard for better dust extraction and to allow possibility of grooving
- Maximum blade size 350 mm diameter
- Maximum depth of cut 125 mm
- Machine supplied with separate angle cutting fence

Specification

Main saw blade diameter max.	Ø 350 mm
Max. cutting height with blade at 90°	100 mm
Max. cutting height with blade at 45°	70 mm
Rectified cast iron fixed table dimension	620x1000 mm
Main blade speed	3000 / 4000 / 5000 / 6000 RPM
Sliding table length	380 x 3200mm
Main saw bore	Ø 30 mm
Main motor power	7.5HP (5.5KW)
Scoring saw blade	Ø 120mm
Scoring motor power	1HP (0.75KW)

Scoring blade speed	8000 RPM
Cutting width	1300 mm
Saw table extension	800 mm
Cross cut fence manual movement	Yes
With Mitre fence	Yes
Manual control for cutting width adjustment	Yes
Manual control for blade tilting adjustment	Yes
Manual control for main saw height adjustment	Yes
Manual control for scoring saw height adjustment	Yes
Manual control for scoring + / - direction adjustment	Yes
With Luxurious Overhead saw guard	Yes
With digital display for the tilting of saw blade	Yes
With digital display for the rpm of saw blade	Yes
With tool frame	Yes
With Clamping shoe	Yes
Main channel dust collection	Ø 125 mm
Lux saw guard dust collection	Ø 75 mm

Packing size	2270 x 1300 x 1100 mm + 3330 x 470 x 330 mm
N.W / G.W.	820 kg / 1000 kg + 187 kg / 247 kg

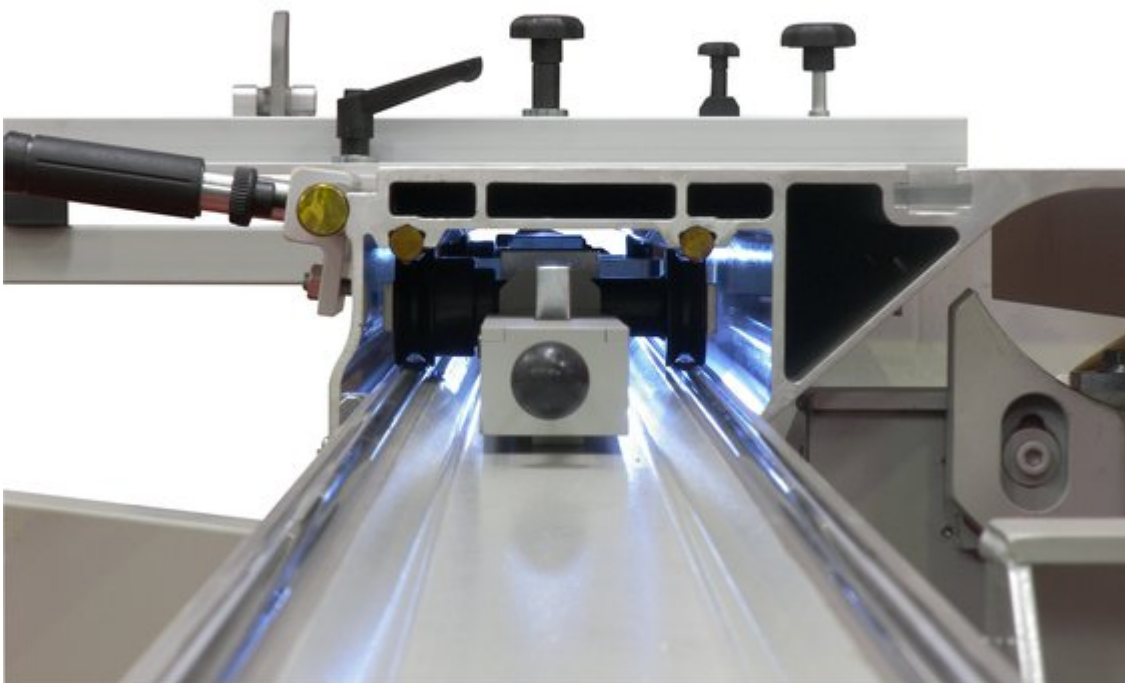

Heavy duty sliding table of multi chamber construction using solid hardened and chromed steel guides with large diameter 'dumb bell' rollers to ensure an easy glide.

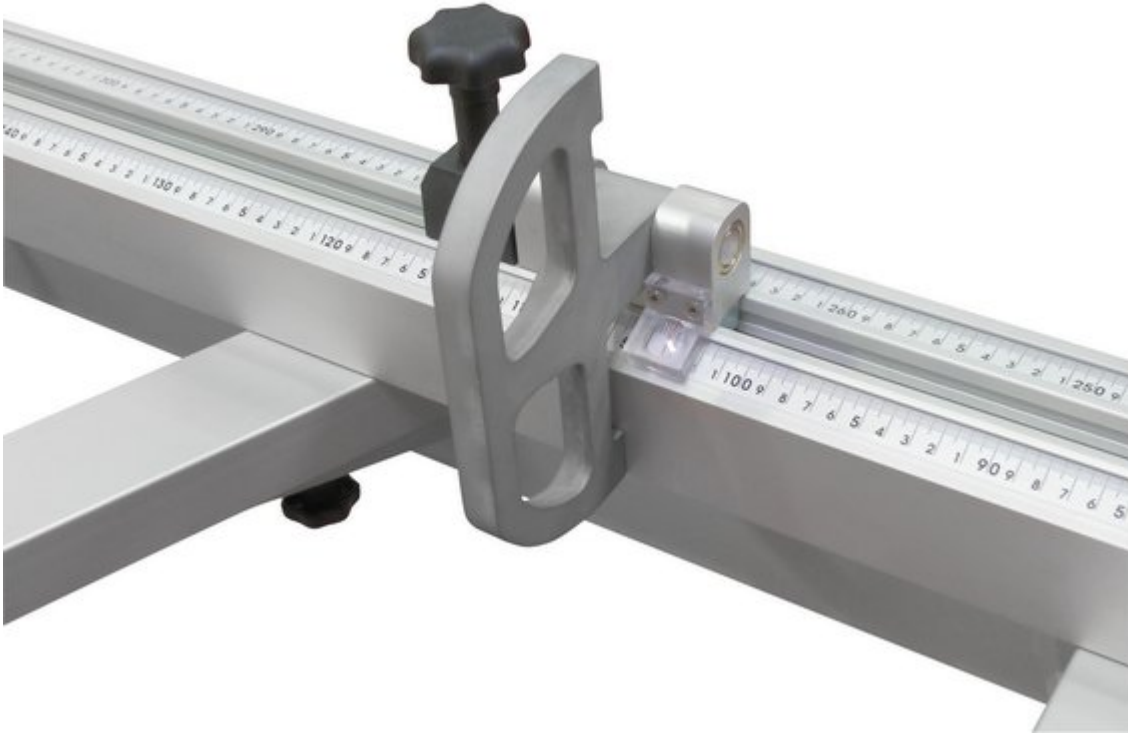

Heavy duty flip stops

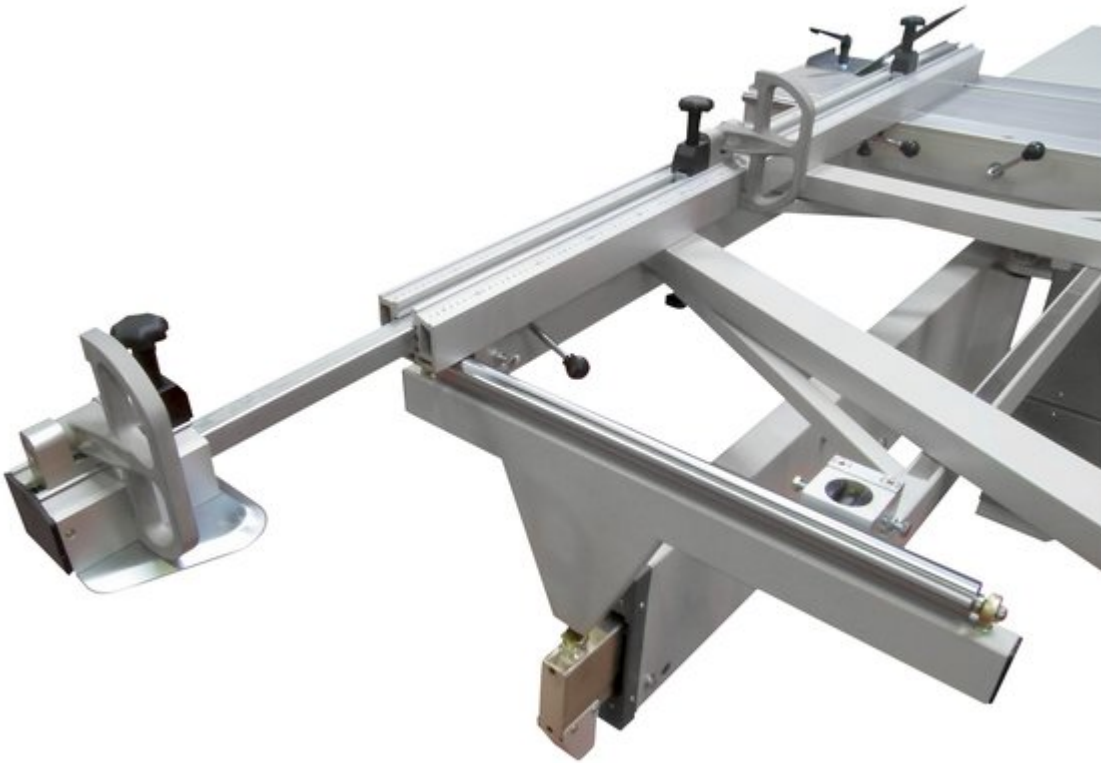

Heavy duty telescopic cross cut fence



Heavy duty rip fence mounted on a solid 50mm diameter chromed steel bar complete with finr adjustment

Find out more about this machine and the rest of the range at the Genisis X-Type Panel Saws (<http://ukpanelsaws.co.uk>) website.

POA

`<p></p>`